

SR10T 产品说明

一、产品概述

- 内置高性能，低功耗微处理器
- 实用的报警功能
  - 断相
  - 过热
  - 过流
  - 负载断线
- 一路继电器输出
  - 3A AC250V
  - 3A DC30V
- 最大电流150A
- 便于集中控制的RS485通讯，可扩展Profibus。

二、安装尺寸

2.1、0-40A

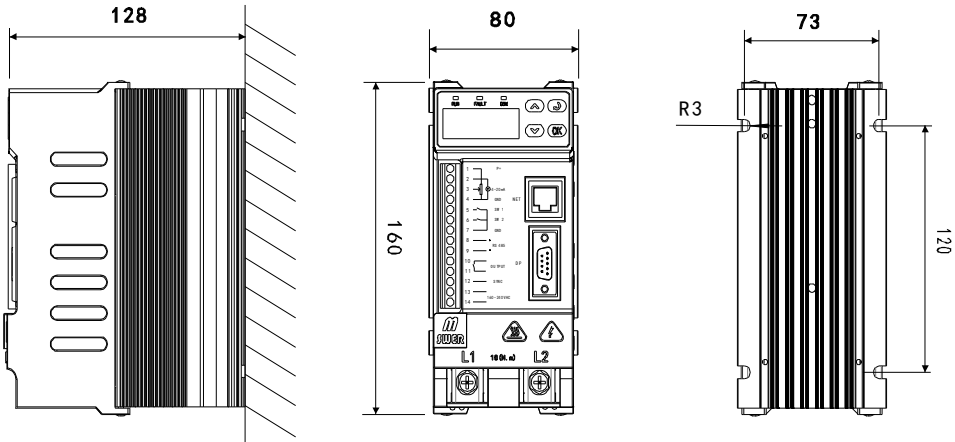

(单位尺寸为:mm)

2.2、75-150A

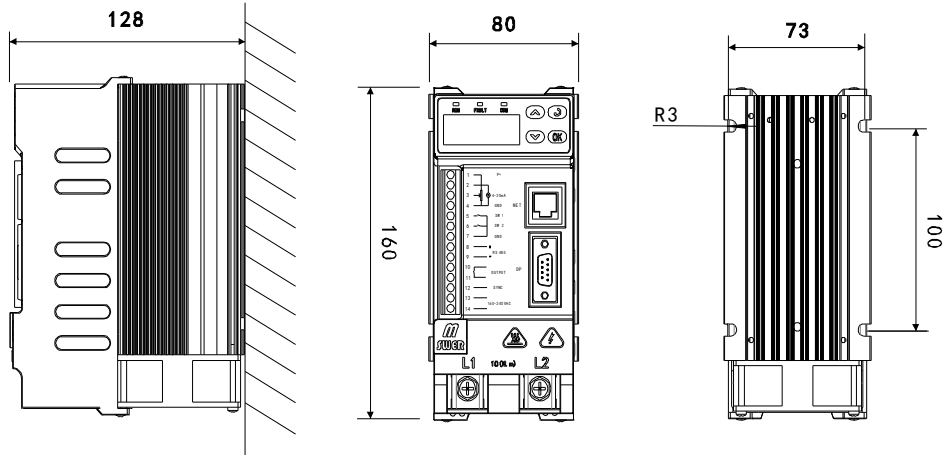

三、安装尺寸

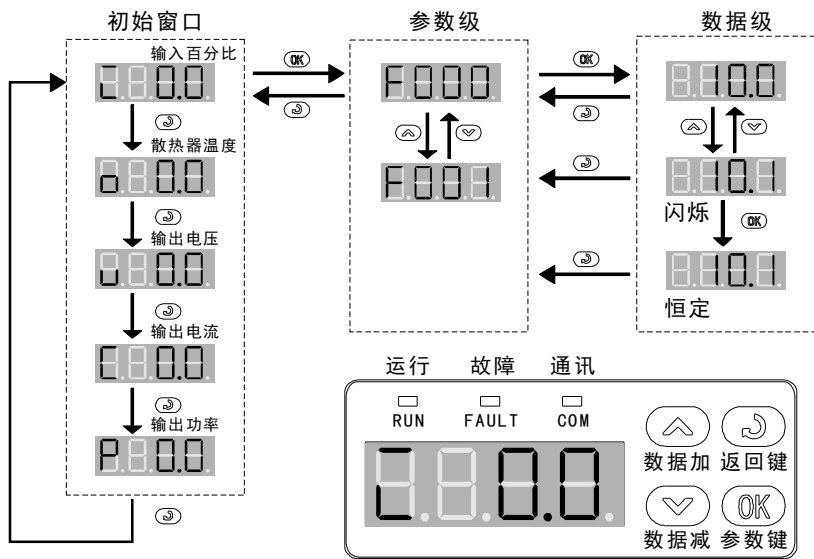

四、端子说明

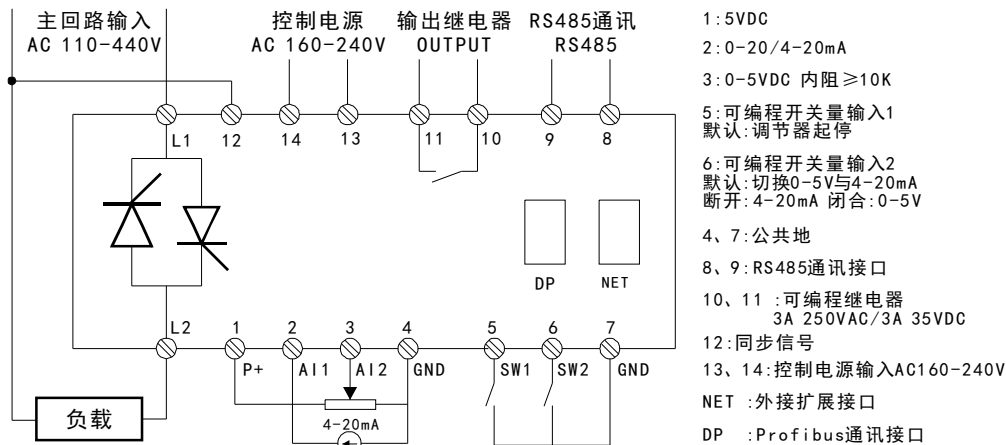

五、通讯

SR10-T系列功率调节器支持MODBUS通讯协议。MODBUS支持3、4、6、16共4种功能，F-35从站地址：1-247，F-36波特率：2400 4800 9600 19200 38400，F-37数据格式：8n2 8e1 8o1三种数据格式。参数值是16位无符号寄存器，不支持小数点，如要写56.7需先调整为整数567后再写。  
注意：每帧数不能超过20个字节，所以每帧数最多读取10个参数。

▶ 读保持寄存器帧格式

0	1	2	3	4	5	6	7
设备地址	03H	参数地址H	参数地址L	寄存器数H	寄存器数L	CRC H	CRC L

▶ 预置单个寄存器帧格式

0	1	2	3	4	5	6	7
设备地址	06H	参数地址H	参数地址L	数据H	数据L	CRC H	CRC L

六、基本参数说明

以下参数为简明操作参数。参数属性R为只读参数，RW为可读写参数。请在停机状态下修改参数。

参数号	说明	范围值	出厂值	可见更改和属性
F-000	给定值合计	0-100.0 [%] 0.1%	-	F-055=0 R
F-004	输出电压	0-3000.0 [V] 0.1V	-	F-055=0 R
F-005	输出电流	0-3000.0 [A] 0.1A	-	F-055=0 R
F-006	输出功率	0-3000.0 [KW] 0.1KW	-	F-055=0 R
F-030	通讯给定寄存器 通讯给定值写入此参数	0-100.0 [%] 0.1%	0	F-055=35 RW
F-055	菜单权限 0: 只显示只读参数 35: 显示简单应用参数和只读参数	0-3000	0	F-055=0 RW
F-061	给定信号类型 50: 模拟量 51: 数字量	33-54	50	F-055=35 RW
F-065	数字量给定类型 0: 键盘 1: 通讯	0-1	0	F-055=35 RW
F-066	数字给定断电保存 0: 保存 1: 不保存	0-1	0	F-055=35 RW
F-077	额定电压 与铭牌上相同，可根据实际负载修改此参数，达到保护设备的目的。 注意：不能大于铭牌标定值	0-3000 [V] 1V	380	F-055=35 RW
F-086	闭环类型 7: 恒电压 8: 恒电流 9: 恒功率	0-33	7	F-055=35 RW
F-111	控制模式 0: 开环 1: 闭环	0-1 1	1	F-055=35 RW
F-114	触发模式 0: 移相 1: 过零触发	0-1 1	1	F-055=35 RW
F-125	前一次故障类型	-	-	F-055=0 RW
F-127	电源故障保护允许 0: 禁止 1: 报警 2: 报警+继电器 3: 报警+继电器+停机	0-1 1	2	F-055=35 RW
F-128	负载故障保护允许 0: 禁止 1: 报警 2: 报警+继电器 3: 报警+继电器+停机	0-1 1	0	F-055=35 RW
F-129	负载断线门限	10-70 [%] 1%	70	F-055=35 RW
F-133	设备地址 此参数设置Modbus和Profibus地址	1-247 1	123	F-055=35 RW
F-134	波特率 0: 2400 1: 4800 2: 9600 3: 19200 4: 38400	0-4 1	2	F-055=35 RW
F-135	数据格式 0: 8n2 数据位8位，无校验，2个停止位 1: 8e1 数据位8位，偶校验，1个停止位 2: 8o1 数据位8位，奇校验，1个停止位	0-2 1	1	F-055=35 RW
F-140	硬件版本	-	-	F-055=0 R
F-141	软件版本	-	-	F-055=0 R

七、故障与维护

7.1、故障表

故障代码	说明
E002	主电源故障，可能故障原因： 1、主回路进线无电压或与铭牌不相符。 2、端子12脚没有接同步线，参照接线图。
E003	过电流，检测电流大于额定电流1.25倍报警被激活。可能故障原因： 1、负载突然变小或短路 2、晶闸管损坏。
E004	负载断线，断线电流=给定百分比*额定电流*负载门限，电流给定值与实际检测值之差大于断线电流，报警被激活。可能故障原因： 1、负载断开 2、负载电流过小 3、负载断线门限 (F-129)设置过小。
E005	调节器过热，检测到散热器温度大于85°C，报警被激活。可能故障原因： 1、环境温度高于45°C 2、风机损坏 3、风道积灰
E009	调节器过载，负载电流大于调节器额定电流
E010	晶闸管损坏，检测到晶闸管损坏激活报警。

7.2、保养与维护

由于使用环境的温度、湿度、灰尘及振动的影响以及装置内部器件的老化等原因。都有可能造成装置发生故障。因此需要定期对装置保养维护，用户可根据现场实际情况在3-6个月内对装置进行检查和保养。检查内容如下：

- ①、主回路端子连接是否可靠。
- ②、电路板、风道、散热风机灰尘必须全面清理。
- ③、调节器长时间不使用，应3个月通电一次。
- ④、装置储存场所应避免高温、潮湿和金属粉尘。

3、维修/备件

- ①、维修请与迈斯威尔售后服务中心联系
- ②、购买备件请与迈斯威尔售后服务中心联系购买备件。

八、订货号代码

SR10-T □ □ □ - □

单相功率调节器  
 额定电流(A):  
 10A (自冷)  
 25A (自冷)  
 40A (自冷)  
 75A (风冷)  
 100A (风冷)  
 150A (风冷)  
 选件: P Profibus通讯  
 C 以太网通讯  
 T 温度功能  
 R 真有效值  
 ED 外部显示扩展  
 EF 外部反馈扩展

# SR10T Operation Manual

## 1 Product Description

- Built-in High-performance, Low-power Microcontroller
- Efficient cooling solution such small size, light weight
- One relay output
  - 3A AC250V
  - 3A DC30V
- Peripheral Features
  - Support 4-20mA and 0-5V (potentiometer) two given
  - Two switch inputs
  - Wide Range Of Primary Loop Voltages (AC110-440V)
- Practical alarm function
  - Phase failure
  - Overheat
  - Overcurrent
  - Load break
- Max Current 150A
- To facilitate centralized control RS485 communication

## 2 Size

2.1 10-40A

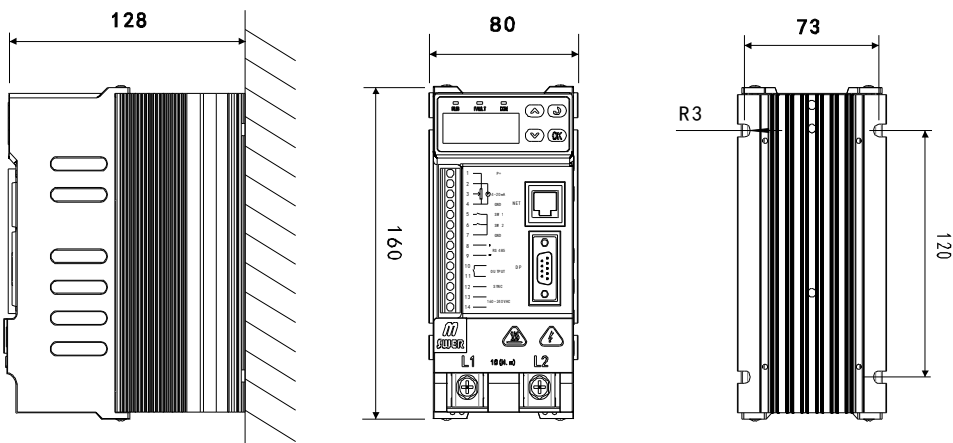

(Unit: mm)

2.2 75-150A

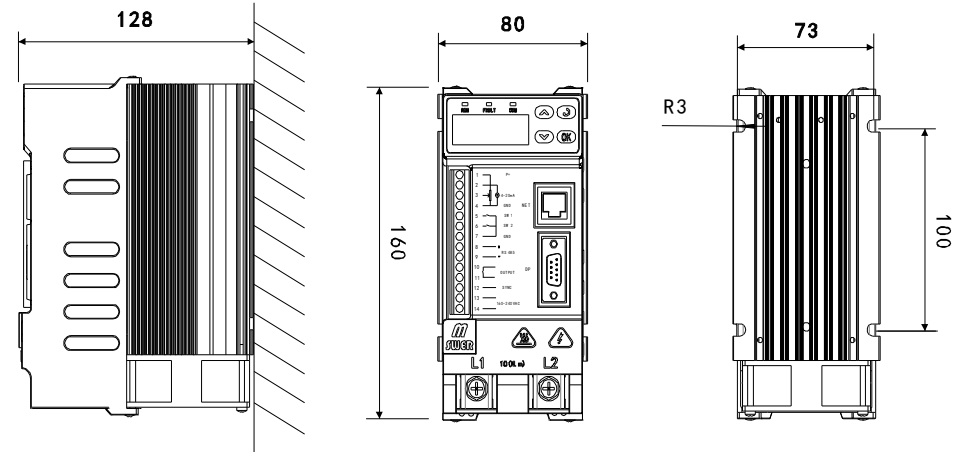

## 3 Keyboard operation

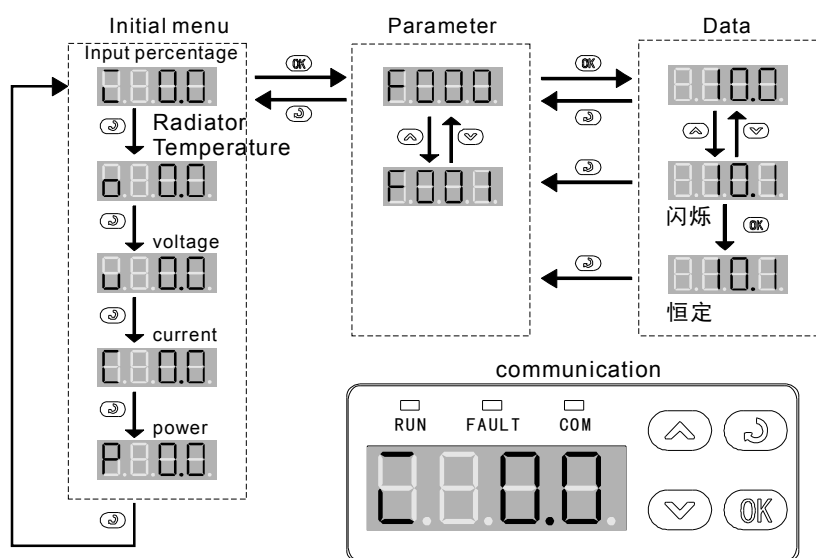

## 4 Terminal description

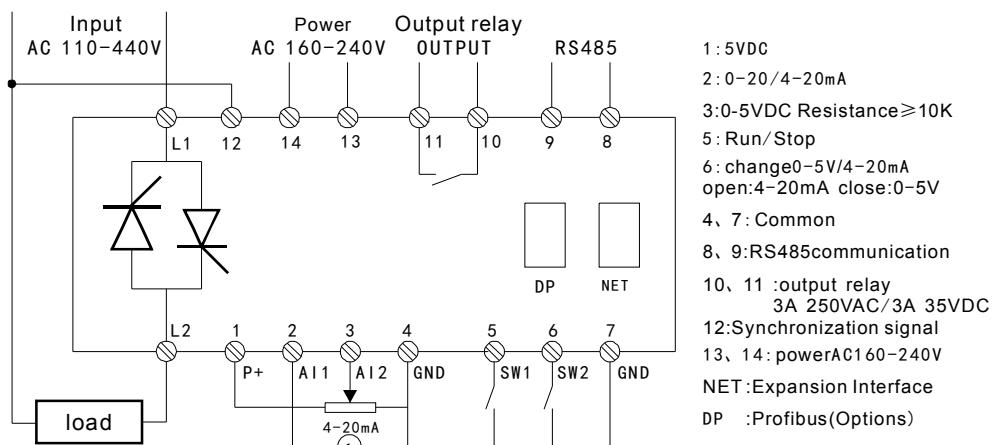

- 1: 5VDC
- 2: 0-20/4-20mA
- 3: 0-5VDC Resistance ≥ 10K
- 5: Run/Stop
- 6: change 0-5V/4-20mA open: 4-20mA close: 0-5V
- 4, 7: Common
- 8, 9: RS485 communication
- 10, 11: output relay 3A 250VAC/3A 35VDC
- 12: Synchronization signal
- 13, 14: power AC 160-240V
- NET: Expansion Interface
- DP: Profibus (Options)

## 5 Communication

SR10T Series power regulator supports Modbus protocols. Modbus supports 3, 4, 6, 16, totally 4 functions, F-133: slave station address: 1-247, F-134 baud rate: 2400 4800 9600 19200 38400. F-135: data format: 8n2 8e1 8o1, 3 types. Parameter value is 16bits no signal register, decimal point is not supported. For example, before writing 56.7, it should be adjusted as 567 and then re-write.

**Notice:** every frame cannot exceed 20 bytes, so every frame can maximum read 10 parameters

### Read Holding Registers frame format

0	1	2	3	4	5	6	7
Addr	Function 03H	Starting Address Hi	Starting Address Lo	No. of Points Hi	No. of Points Lo	CRC H	CRC L

### Preset Single Register frame format

0	1	2	3	4	5	6	7
Addr	Function 06H	Starting Address Hi	Starting Address Lo	Preset Data Hi	Preset Data Lo	CRC H	CRC L

## 6 basic parameter

Above chapter is the brief operation parameter, R: readable parameter, RW: readable and writeable parameter. Please change parameter when regulator stops.

parameter no.	description	range	default	Attributes
F-000	input value	0-100.0 [%] 0.1%	-	F-055=0 R
F-004	output voltage	0-3000.0 [V] 0.1V	-	F-055=0 R
F-005	output current	0-3000.0 [A] 0.1A	-	F-055=0 R
F-006	output power	0-3000.0 [KW] 0.1KW	-	F-055=0 R
F-030	Set-point through communication	0-100.0 [%] 0.1%	0	F-055=35 RW
F-055	Menu Authority 0: Read-only parameter is displayed 35: Display simple parameter and read-only parameter	0-3000	0	F-055=0 RW
F-061	Reference types 50: Analog value set-point 51: Set-point through communication	33-54	50	F-055=35 RW
F-065	Digital given type 0: Keypad set-point 1: communication	0-1	0	F-055=35 RW
F-066	Digital setting power saving 0: saving 1: not saving	0-1	0	F-055=35 RW
F-077	Rated voltage: The same as nameplate. Data can be changed according to actual load, for the purpose of protecting device	0-3000 [V] 1V	380	F-055=35 RW
F-086	Feedback signal type 7: voltage 8: current 9: power	0-33	7	F-055=35 RW
F-111	Feedback Type 0: Open loop 1: closed loop	0-1	1	F-055=35 RW
F-114	Trigger Mode 0: Phase shifter 1: Zero trigger	0-1	1	F-055=35 RW
F-125	Previous fault type	-	-	F-055=0 RW
F-127	Power fault protection enables 0: Disable 1: alarm 2: alarm+relay 3: alarm+relay+stop	0-1	2	F-055=35 RW
F-128	Load fault protection enables 0: Disable 1: alarm 2: alarm+relay 3: alarm+relay+stop	0-1	0	F-055=35 RW
F-129	Load-off threshold	10-70 [%] 1%	70	F-055=35 RW
F-133	device address Setting address of Modbus and Profibus	1-247	123	F-055=35 RW
F-134	baud rate 0: 2400 1: 4800 2: 9600 3: 19200 4: 38400	0-4	2	F-055=35 RW
F-135	Data format 0: 8n2 Date bit 8 bits, no calibration, 2 stop bits 1: 8e1 Date bit 8 bits, parity - checking, 1 stop bits 2: 8o1 Date bit 8 bits, odd parity -checking, 1 stop bits	0-2	1	F-055=35 RW
F-140	Hardware edition	-	-	F-055=0 R
F-141	Software edition	-	-	F-055=0 R

## 7 Fault and maintenance

### 7.1 Fault list

fault code	description
E002	Main power fault, possible fault reason: 1. No voltage of mail loop or not the same of nameplate. 2. Synchronous cable of terminal 12 is not connected, please refer to the wiring drawing.
E003	Overcurrent, measured current exceeds 1.25 time of rated current, possible reason: 1. Load changes rapidly or short-circuit. 2. Thyristor breaks.
E004	Load-off, load off current = set-point percentage * rated current * load threshold, alarms when difference between set-pint and measured current is bigger than load off current. Possible reason: 1. Load off 2. Load current is small 3. Setting of (F-129) is small
E005	Overheat of regulator, heat-sink temperature is bigger than 85, possible reason: 1. Ambient temperature is higher than 45. 2. Fan breaks. 3. Dust on the ventilation path.
E009	Overload of regulator, load current is bigger than rated current of regulator.
E010	Thyristor breaks, Thyristor damage detected alarm is activated.

### 7.2 daily maintenance

Fault might happen because of using temperature, humidity, dust and some other reason, daily maintenance is needed, user can do the check and maintain within 3~6 months, checking lists are as below:

- 1: Main loop connector.
  - 2: Clean PCB board, ventilation, fans.
  - 3: Regulator should be electricity every 3 months if not use.
  - 4: Prevent from high temp. humidity and metal powder location.
- 9.3 spare part/maintain
- 1: Please contact service centre +86 0838-2443568 for maintenance.
  - 2: Please contact MSWER for buying spare parts.

## 8 Order no. code

SR10T    -

Single-phase power regulator

Rated current (A):  
10A (self-cooling)  
25A (self-cooling)  
40A (self-cooling)  
75A (air-forced)  
100A (air-forced)  
150A (air-forced)

Optional: P Profibus communication  
C Ethernet  
T Temperature function  
R RMS vaue  
ED External display  
EF External feedback